



Specification

Futureenergy, 24V 1kW Permanent Magnet Generator

Prepared By

D Nangle, Sept 2016

Contents

Dimensions	3
Specification	4
Graph: Power vs RPM @ Load Resistances (Ω)	5
Graph: Terminal Voltage vs RPM @ Load Resistances	6
Graph: Terminal Current vs RPM @ Load Resistances	7
Graph: DC Load Voltage vs RPM @ Load Resistances	8
Graph: DC Load Current vs RPM @ Load Resistances	9
Graph: Open RMS L/L Voltage vs RPM	10
Graph: Open DC Voltage vs RPM	11
Graph: Fundamental Frequency vs RPM	12
Graph: Efficiency vs Current @ 750 RPM Constant	13
Graph: Cogging Torque	14

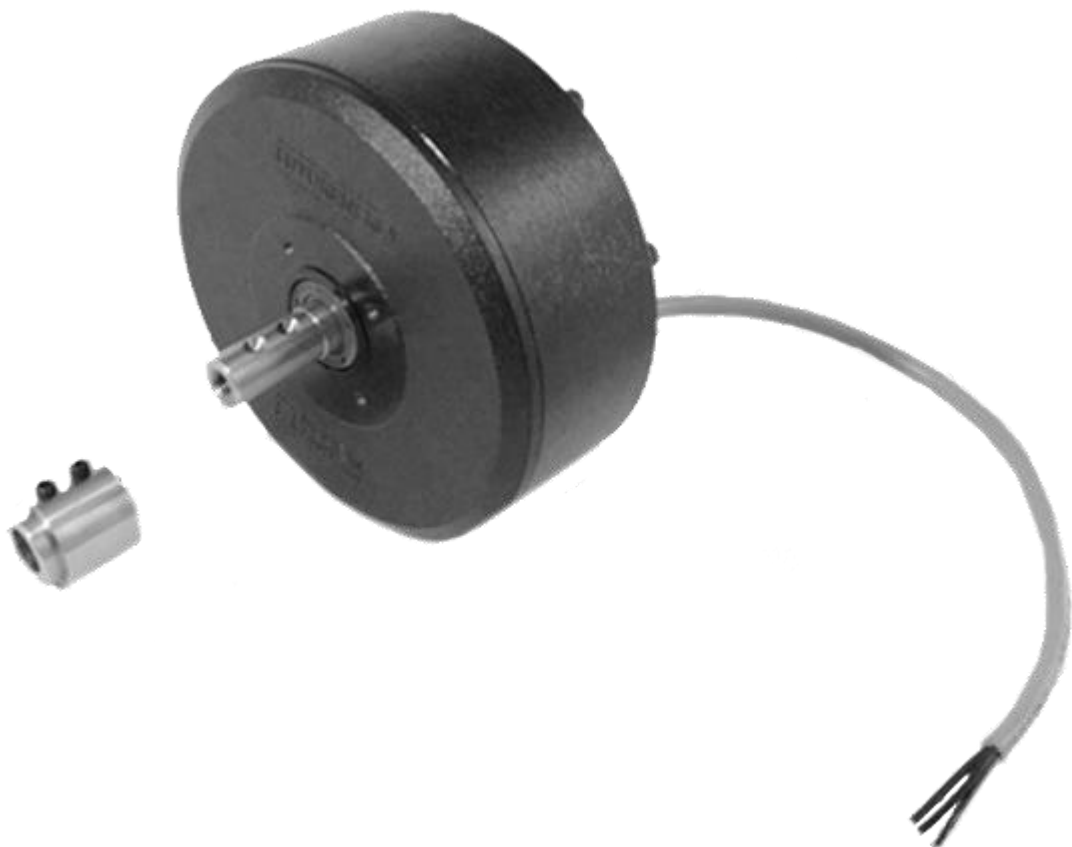

Dimensions

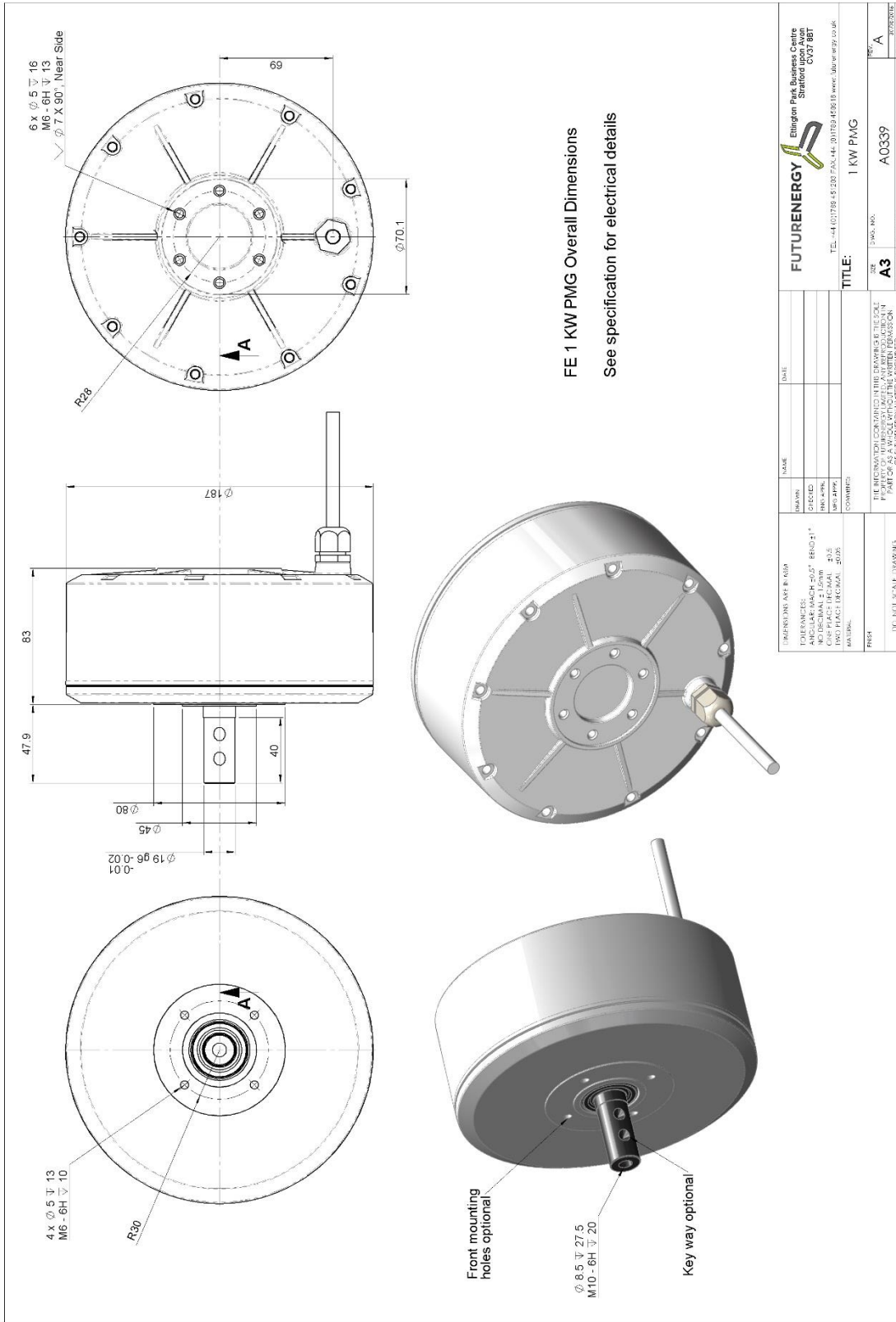

Specification

Nominal Rated Power	1 kW
Nominal RPM	750 RPM
Line / Line RMS Open Voltage	48V (24V DC @ 300 RPM)*
Nominal Line Current	16 Amps**
Configuration	3 Phase, Star wound AC output
Line / Line Winding Resistance	0.4 Ohms
Nominal Self Inductance	0.4168 mH
Maximum Over-Load Power	1.5 kW
Efficiency	92 %
Maximum Cogging Torque (Excluding Shaft Seals)	< 0.5 Nm
Duty @ Nominal Power	100%
Insulation Class	H
Mounting	Any
Shaft Material	Stainless Steel
Magnet Material	NdFeB
Shell Material	LM25 Aluminium
Protection	IP54
Poles	12
Winding code	P123-T14-W1.5

* DC Voltage requires an additional bridge rectifier

** Voltage and current will depend on connected electrical system. For example; a system charging 24V battery bank will reduce generator voltage to the battery charge voltage and increase current. Values quoted assume fixed resistance loads.

Graph: Power vs RPM @ Load Resistances (Ω)

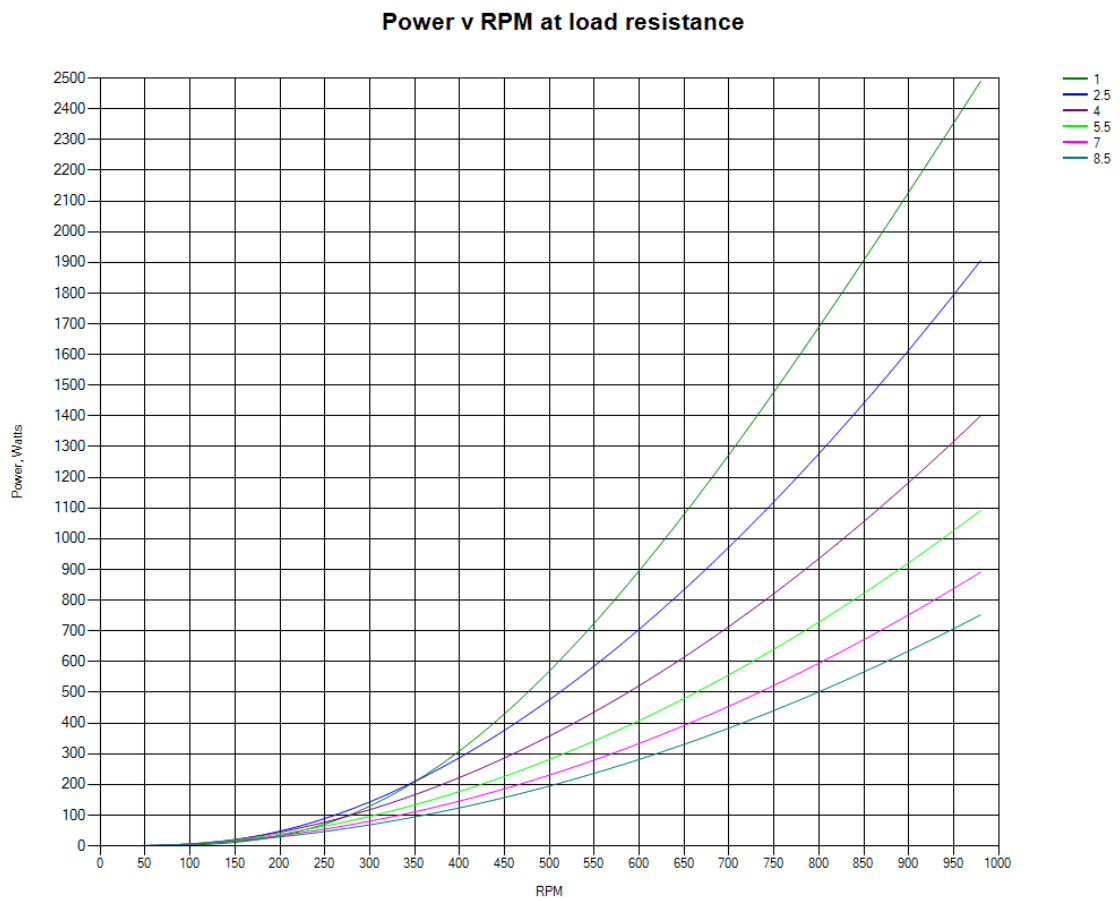

Graph: Terminal Voltage vs RPM @ Load Resistances

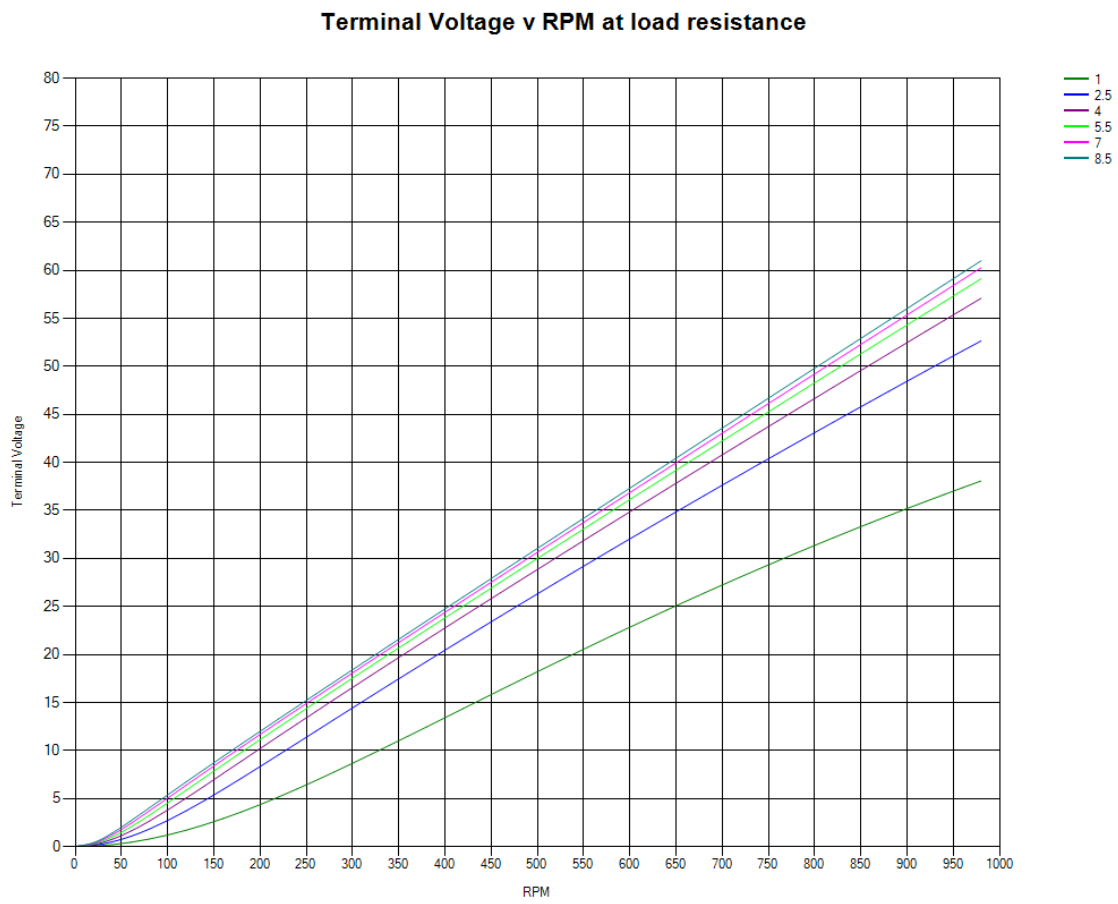

Graph: Terminal Current vs RPM @ Load Resistances

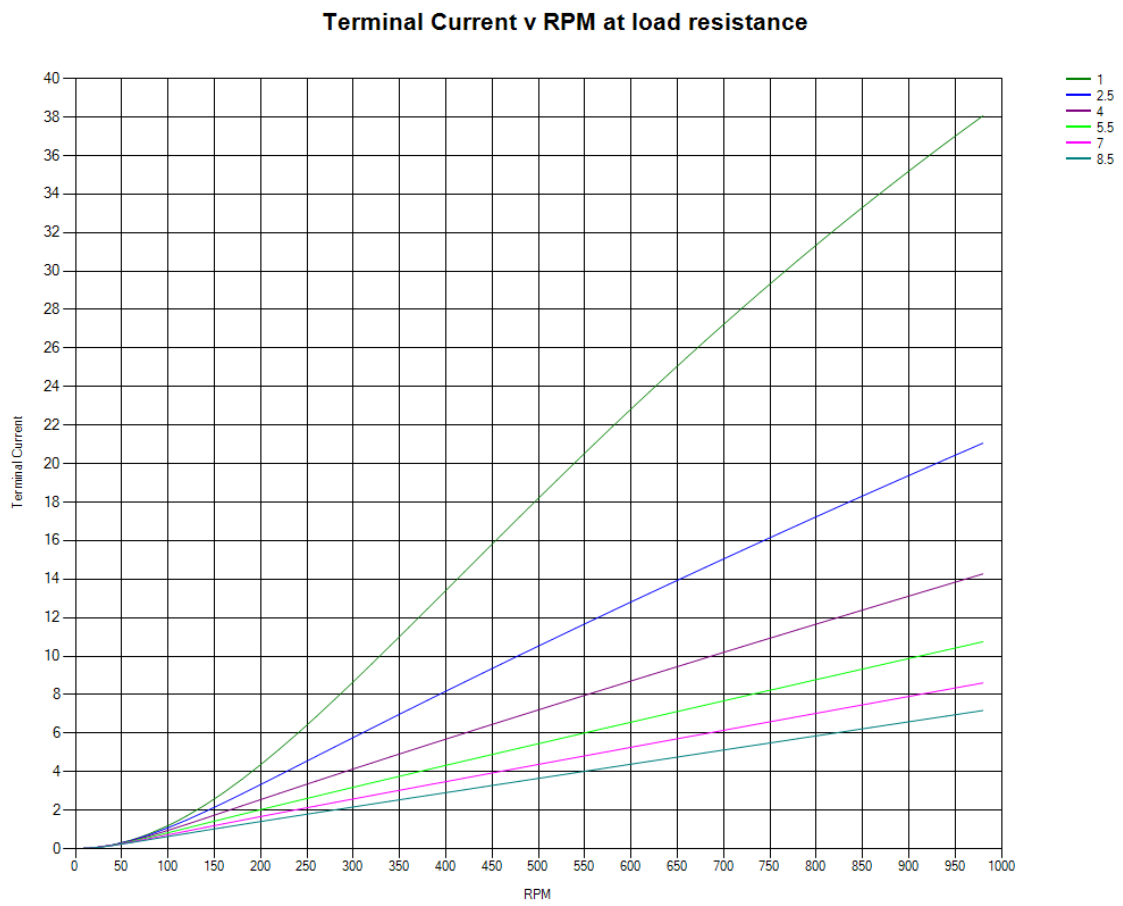

Graph: DC Load Voltage vs RPM @ Load Resistances

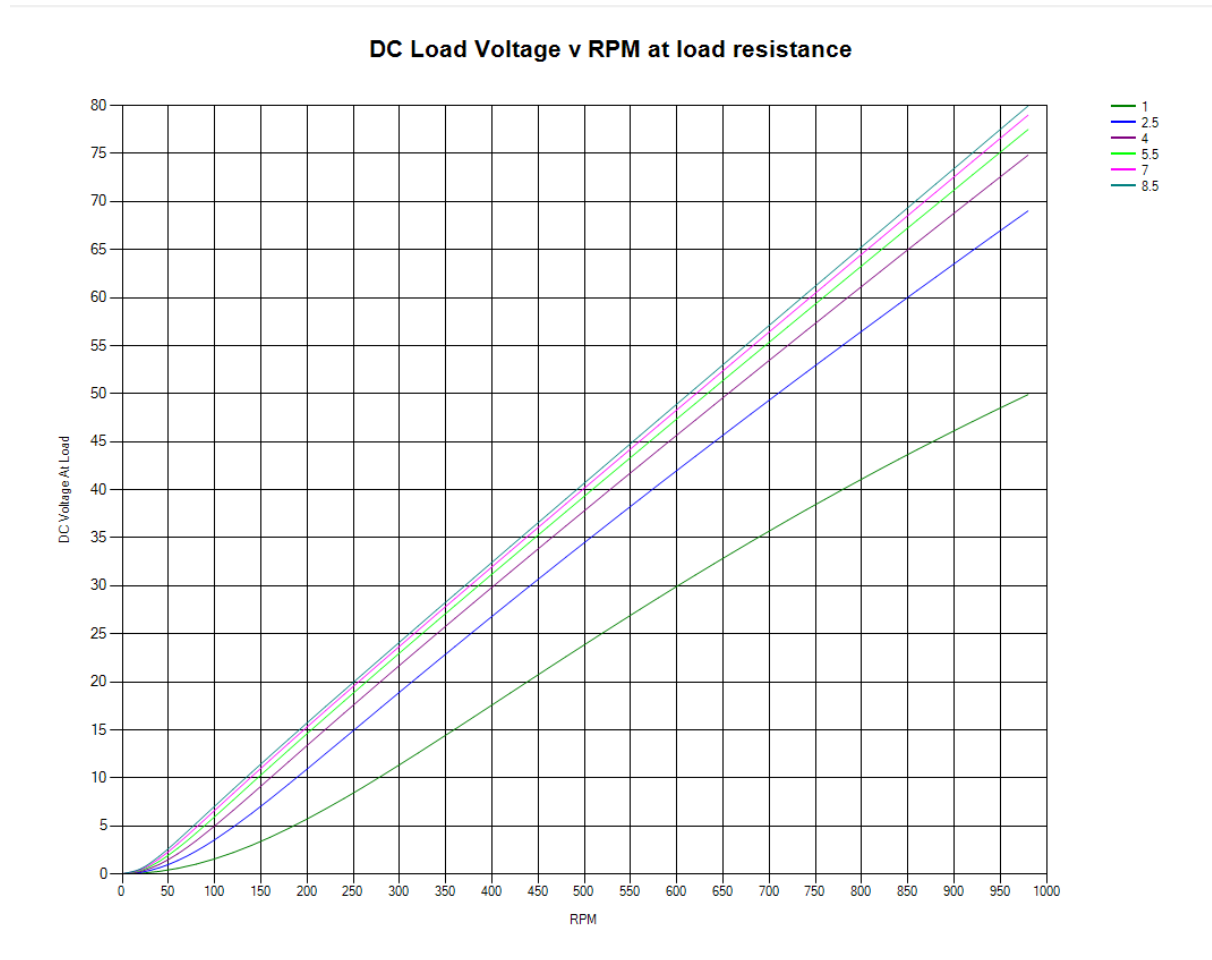

Graph: DC Load Current vs RPM @ Load Resistances

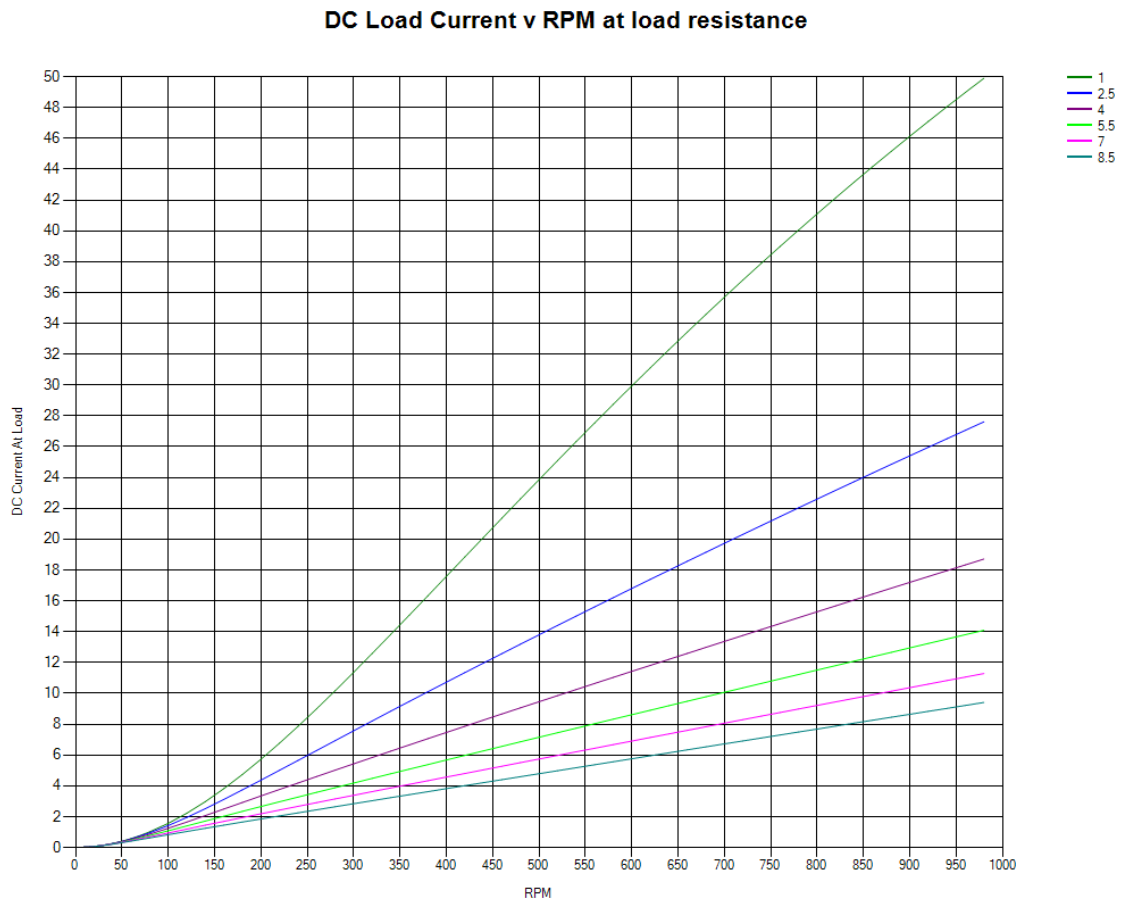

Graph: Open RMS L/L Voltage vs RPM

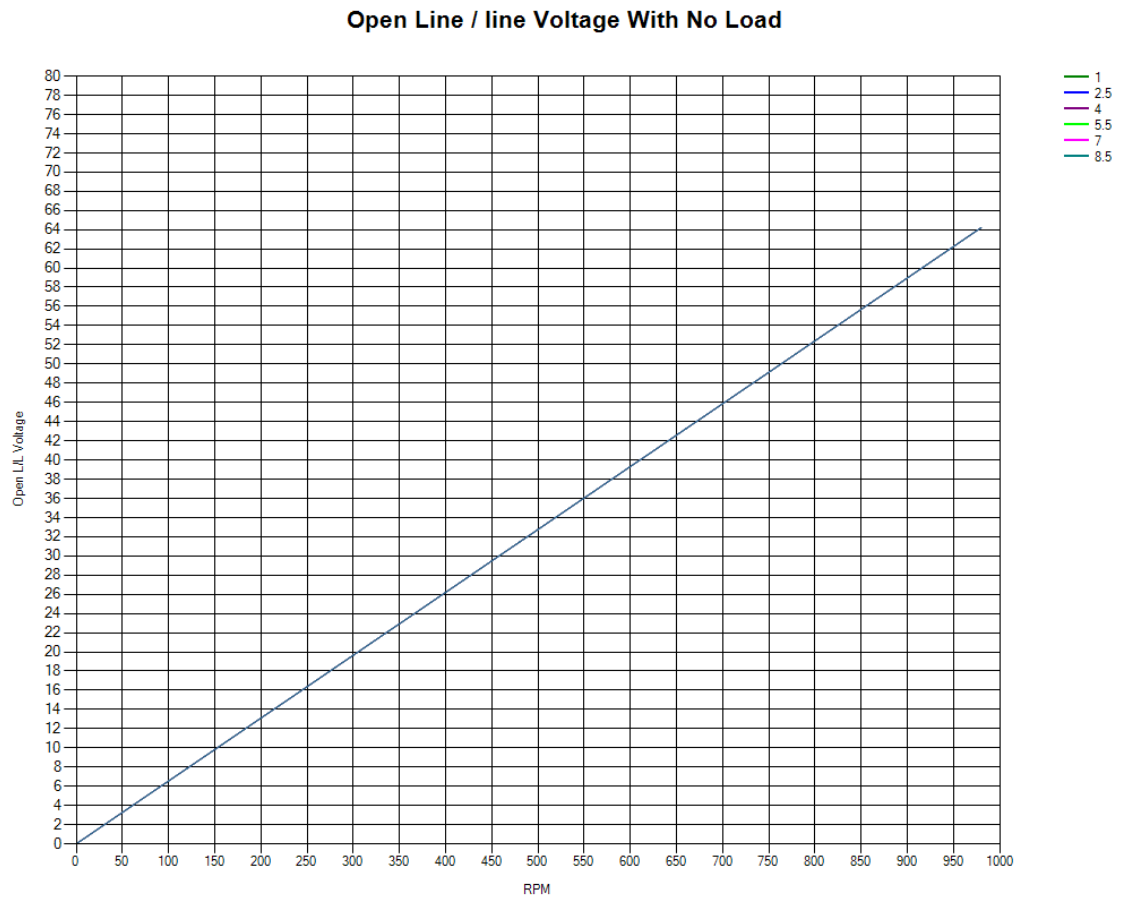

Graph: Open DC Voltage vs RPM

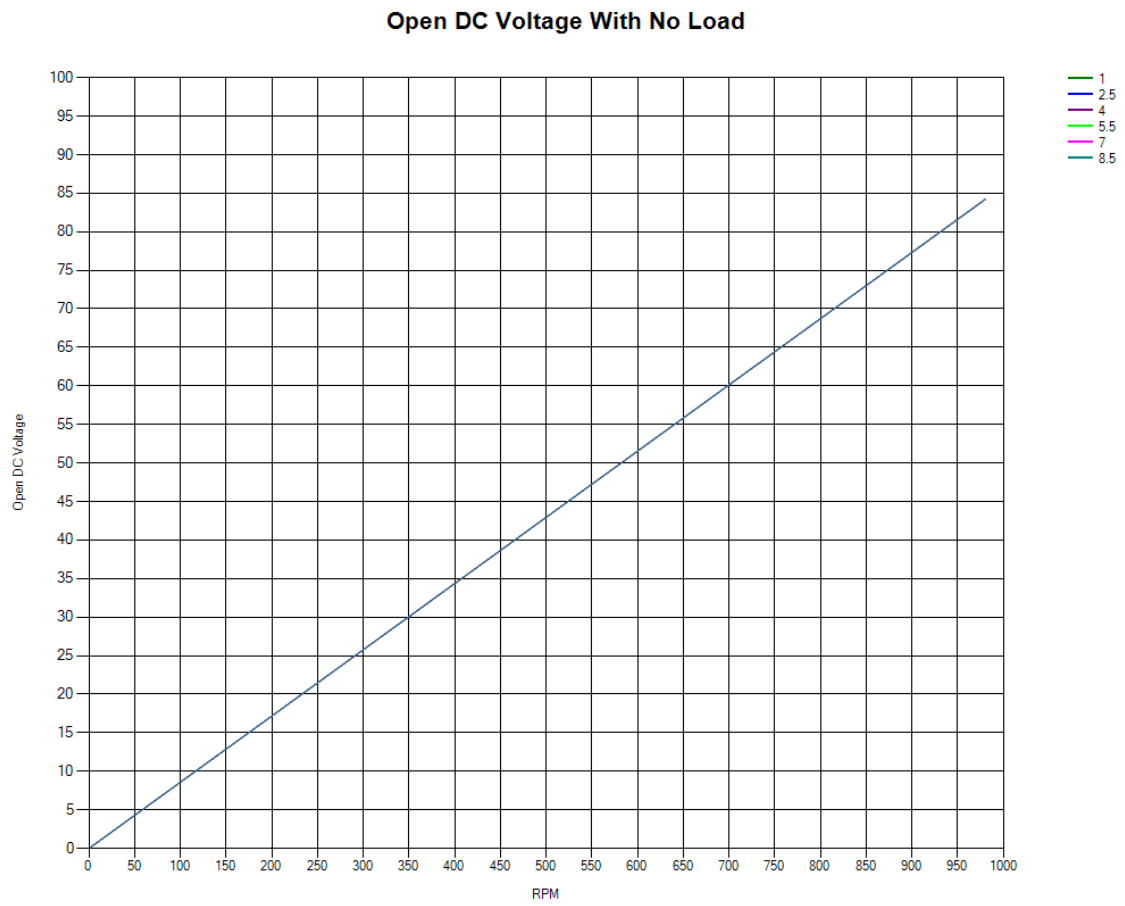

Graph: Fundamental Frequency vs RPM

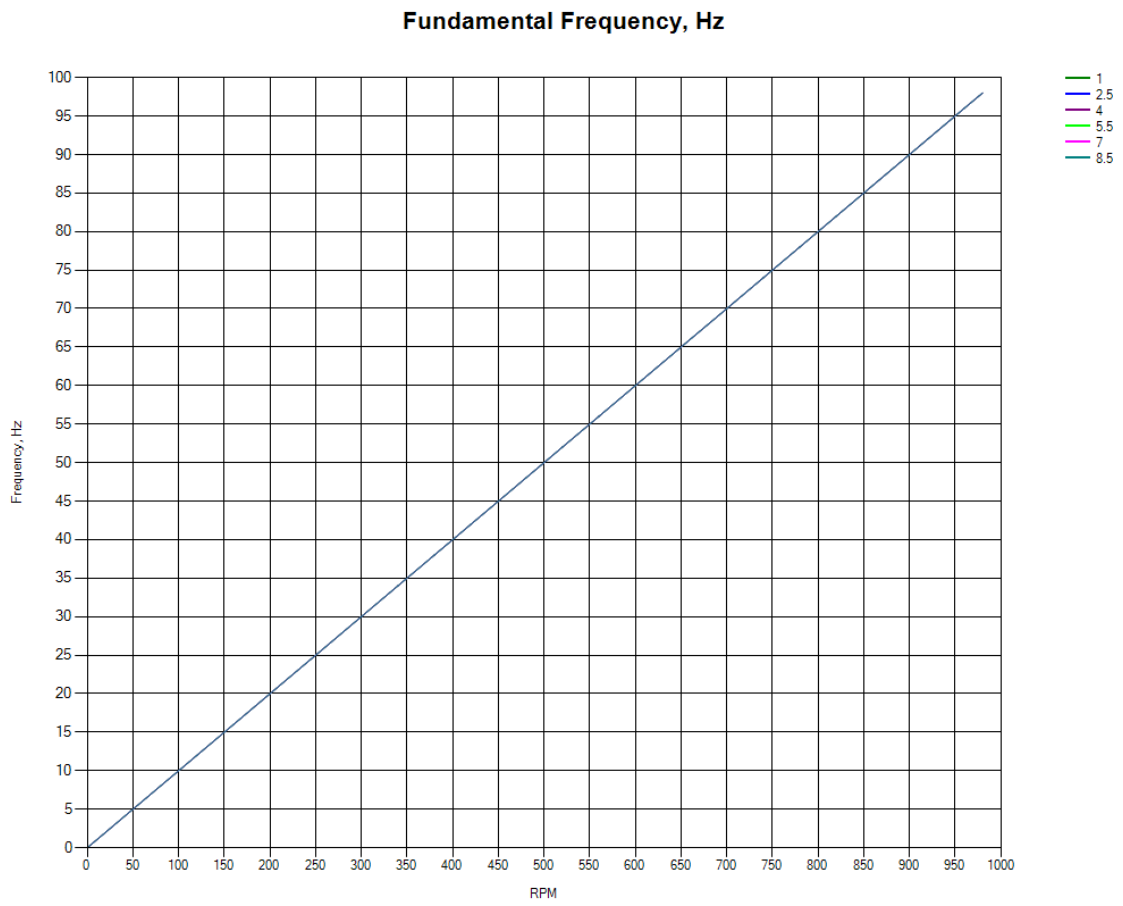

Graph: Efficiency vs Current @ 750 RPM Constant

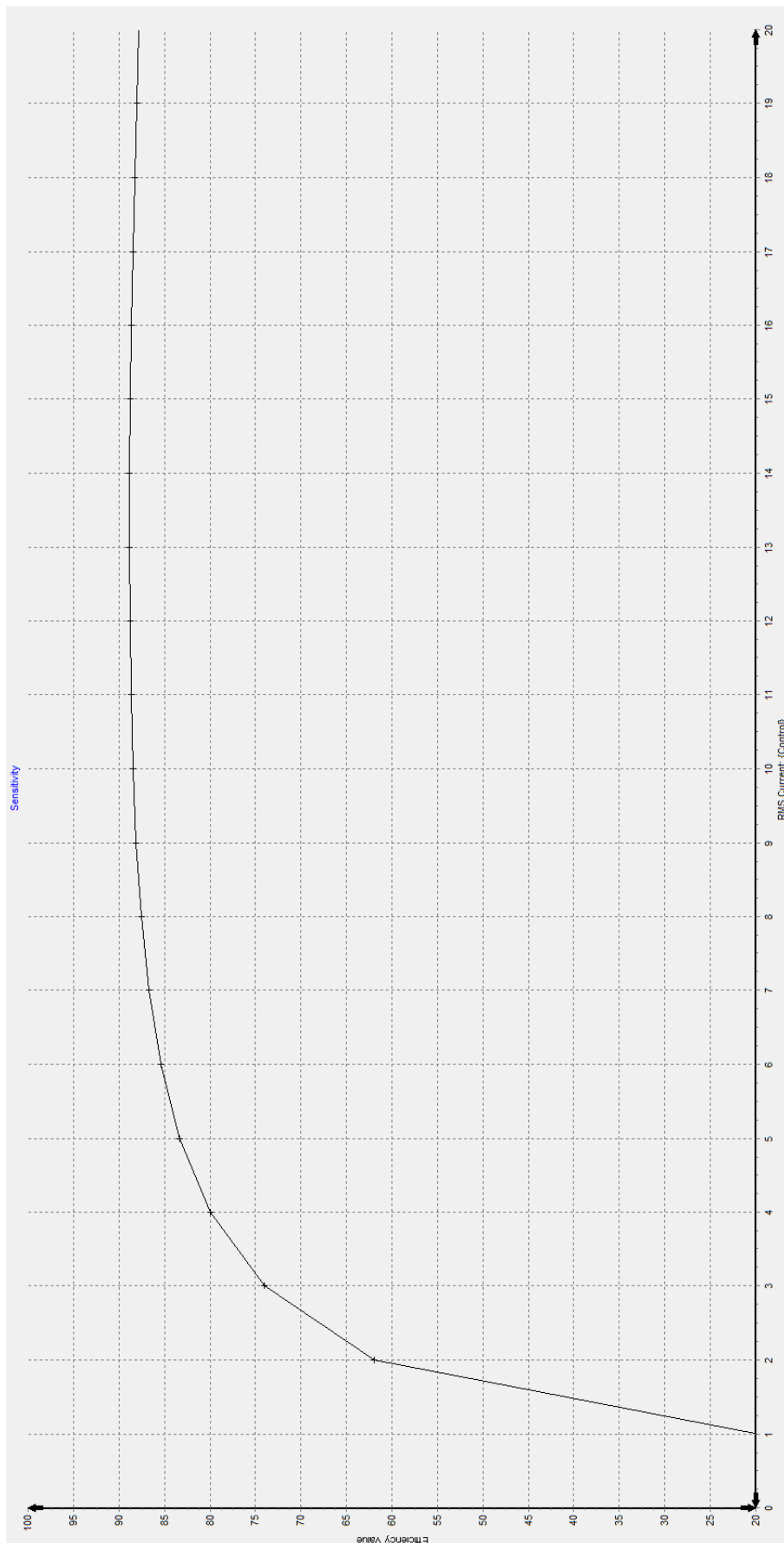

Graph: Cogging Torque

