

(12) STANDARD PATENT APPLICATION (11) Application No. AU 2021282556 A1
(19) AUSTRALIAN PATENT OFFICE

(54) Title
ELECTRIC ENERGY GENERATOR AND ELECTRIC ENERGY GENERATION METHOD

(51) International Patent Classification(s)
H02M 3/145 (2006.01) **H02M 3/156** (2006.01)
H01J 3/02 (2006.01) **H02M 5/275** (2006.01)
H01J 37/06 (2006.01) **H02M 5/453** (2006.01)
H01J 37/15 (2006.01)

(21) Application No: **2021282556** (22) Date of Filing: **2021.12.11**

(30) Priority Data

(31) Number	(32) Date	(33) Country
2021-096283	2021.06.09	JP

(43) Publication Date: **2023.01.05**

(43) Publication Journal Date: **2023.01.05**

(71) Applicant(s)
Andrea Rossi

(72) Inventor(s)
Rossi, Andrea

(74) Agent / Attorney
Pizzeys Patent and Trade Mark Attorneys Pty Ltd, PO Box 291, WODEN, ACT, 2606, AU

Abstract

The creation of these virtual particles is favoured by the high density of allowable energy states in vacuum, while they are hindered by the relatively low number of permitted states in an ordinary metallic conductor. This difference may be exploited to generate a high efficiency electric energy generator and this is what this invention has been made for.

The objective is solved by An electricity generator set made by a conductive hollow enclosure, made by metals or quartz containing conductors, connected with a power source that powers an electron gun made by a tungsten-hafnium alloy, upon which is a grid, so that the electrons hit a target at the opposite side, while a magnet forces the electrons to run in straight line toward the target, and the enclosure is grounded until its hollow is saturated, so that when it is saturated MOSFET impedes the electrons to go to ground, and a diode has to allow the electrons go to a capacitor and from the capacitor to a load.

Title of Invention

ELECTRIC ENERGY GENERATOR AND ELECTRIC ENERGY GENERATION METHOD

Technical Field

[0001]

This patent derives from theories bound to the concept of space charge, vacuum polarization and virtual particles and is related to the spontaneous formation of an electron cloud around a cathode heated in a vacuum.

Background Art

[0002]

The physics theory at the base of this invention has been published by the inventor on Researchgate in January 2019:

www.researchgate.net/publication/330601653_E-Cat_SK_and_long_range_particle_interactions

and is realized by an entropic pump, wherein point zero energy foreseen by the uncertainty principle of Heisenberg subject to dV/dt with high dV causes increase of the Zitterbewegung of electrons and the Aharonov-Bohm effect, that causes electrons phase change, that causes formation of clusters of electrons in phase, that causes minor entropy, thermal capacity and freedom degrees, that causes transfer of energy to electrons not in phase, causing gain of energy.

[0003]

Although well known and exploited since the early years of vacuum tube technology, the space charge effect has not a well defined theory, because the formation of a stable space charge is supposed to be prevented by the Coulombian forces between electrons. But we discovered experimentally that the repulsion force can be screened by a vacuum polarization generated by the formation-annihilation of virtual charges pairs

as a consequence of quantum fluctuations predicted by Heisenberg uncertainty principle.

[0004]

The lifetime of such particle-antiparticle couples is inversely proportional to their mass-energy, but during their short existence may act as the charges in the solid dielectric of a capacitor that, screening the electric field, lowers the voltage required to accumulate a charge in the capacitor plates.

Related Art Documents

Patent Literature

- [Patent literature 1] US 9,115,913 B1
- [Patent literature 2] US 6,465,965 B1
- [Patent literature 3] US 9502202 2016
- [Patent literature 4] US 5502354 1986
- [Patent literature 5] US 7379286 2008
- [Patent literature 6] US 9306527 2016
- [Patent literature 7] US 3670494 1972

Non-Patent Literature

[Non-patent literature 1] Aharonov Y. and Bohm D. Significance of Electromagnetic Potentials in the Quantum Theory, *Physical Review*, 115: 485-491, 1959

[Non-patent literature 2] Hestenes D. Zitterbewegung Modeling, *Foundations of Physics*, 23(3): 365-387, 1993

[Non-patent literature 3] Dirac P.A.M. Nobel lecture, *Theory of Electrons and Positrons*, Nobel Lectures, Physics 1922-1941, 1965

[Non-patent literature 4] Feynman R.P. *QED: The Strange Theory of Light and Matter*, Penguin Books, Penguin 1990

[Non-patent literature 5] Giorgio Vassallo et Al.: Maxwell-Dirac Theory and Occam's Razor: Unified Field, Elementary Particles, and Nuclear Interactions, Amazon 2019

[Non-patent literature 6] Andrea Rossi: Ecat SK and long range particle interactions

www.researchgate.net/publication/330601653_E-Cat_SK_and_long_range_particle_interactions

[0007]

Summary of Invention

Technical Problem

The creation of these virtual particles is favoured by the high density of allowable energy states in vacuum, while they are hindered by the relatively low number of permitted states in an ordinary metallic conductor. This difference may be exploited to generate a high efficiency electric energy generator and this is what this invention has been made for. Such energy is made by a plasma whose gain in photons is turned into electric energy by walls inside the hollow solid hereunder described, that is layered by alloys of Gallium, Indium, Arsenic, Phosphorus, Germanium, Gold and Bismuth.

Nobody has succeeded until today to realize and put in operation an electric energy generator based on the concept of space charge and the apparatus of this invention responds to the task to make operative the space charge for the first time.

[0008]

This apparatus is totally different from any existing electric energy generator of electricity, light and heat and should have a higher efficiency, as we have shown in the experiments here reported.

Solution to Problem

[0009]

According to one embodiment of the present invention, the following [1] to [35] are provided:

[1] An electricity generator set made by a conductive hollow enclosure, made by metals or quartz containing conductors, connected with a power source that powers an electron gun made by a tungsten-hafnium alloy, upon which is a grid, so that the electrons hit a target at the opposite side, while a magnet forces the electrons to run in straight line toward the target, and the enclosure is grounded until its hollow is saturated, so that when it is saturated MOSFET impedes the electrons to go to ground, and a diode has to allow the electrons go to a capacitor and from the capacitor to a load.

[2] Electricity generator as described in [1], wherein the MOSFET is piloted with an NPN transistor put between two resistances and powered by a frequency generator.

[3] Electricity generator as described in [2], wherein one resistance is put between a DC energy source and the NPN transistor and the other is put between the pilot transistor and the connection with the frequency generator.

[4] Electricity generator as described in [2] or [3] wherein a DC current source is put between the MOSFET and the NPN transistor.

[5] Electricity generator as described in any one of [1]-[4] wherein the MOSFET generates the frequency necessary to alternate the phase in which the electrons go to ground and the phase during which they go to the load.

[6] Electricity generator as described in any one of [1]-[5] wherein a vacuum pump makes the vacuum in the enclosure through a valve and the vacuum contains Ar, or other gases and metals, possibly the enclosure being sealed at a fixed vacuum grade.

[7] Electricity generator as described in any one of [1]-[6] wherein the electron gun is powered by a DC power source with a voltage lower than the voltage of the wire that connects it with the ground, that is fed by means of a DC current source.

[8] Electricity generator as described in any one of [1]-[7] wherein the DC current that go to the electrons gun and the ground wire is modulated by means of a variable transformer (Variac).

[9] Electricity generator, as describe in any one of [1]-[8], wherein the electron gun is electrically insulated from the enclosure by means of proper insulating materials.

[10] Electricity generator, as described in any one of [1]-[9], wherein the enclosure is double walled by a heat exchanger to recover the heat dissipated from the generator.

[11] Electricity generator, as described in [10], wherein the heat recovery exchanger can use as a coolant any gaseous or liquid medium.

[12] Electricity generator, as described in any one of [1]-[11], wherein all the components and the power sources of the generator are connected to the ground by the same omnibus.

[13] Electricity generator, as described in any one of [1]-[12], wherein the electron gun is charged by means of a source that is grounded through a DC line to maintain a higher potential between the cathode and the ground respect the voltage between the cathode and the grid connected to the enclosure.

[14] Electricity generator, as described in any one of [1]-[13], wherein the capacitor must have a voltage not higher than the breakdown voltage of the MOSFET and a capacitance higher than the capacitances of the enclosure and the MOSFET combined.

[15] Electricity generator, as described in any one of [1]-[14], wherein voltages, amperages, capacitances, dimensions, tesla, choice of materials depend on the power of the generator.

[16] Electricity generator, as described in any one of [1]-[15], wherein the MOSFET is connected to a NPN transistor, put between two resistances, so that the signal arriving from a frequency generator is maintained exactly at the value at which the MOSFET has to work and one DC source is put between the NPN transistor and the generator and another DC source is put between the MOSFET and the ground.

[17] Electricity generator, as described in any one of [1]-[16], wherein the MOSFET and the NPN transistor are cooled by heat sinks and fans.

[18] Electricity generator, as described in any one of [1]-[17], wherein a resistance polarizes the NPN pilot, a resistance polarizes the zener, a resistance brings the gate of the MOSFET to a +20V voltage respect the source when the NPN transistor is barred, a resistance limits the current to the led of the opto-coupler.

[19] Electricity generator, as described in any one of [1]-[18], wherein a condenser accumulates the electrons to be sent to the load, a condenser lowers the impedance of the zener, a condenser is for by pass of the 24V battery, a condenser is connected to the opto-coupler, a condenser is a by-pass of the cathode.

[20] Electricity generator, as described in any one of [1]-[19], wherein is a zener to reverse the current when the voltage is reached between the enclosure and the MOSFET.

[21] Electricity generator as described in [20] wherein a diode allows the current to go toward the capacitor when the voltage is reached.

[22] Electricity generator as described in [20] wherein an opto-coupler isolates the frequency generator (Siglent) from the switch circuit.

[23] Electricity generator as described in [20] wherein a NPN transistor addresses the current to the SiC-MOSFET.

[24] Electricity generator, as described in [20], wherein a SiC-MOSFET regulates the alternate cycles of the process, allowing the current to go to ground or to the enclosure.

[25] Electricity generator, as described in any one of [1]-[24], wherein the plasma is surrounded by alloys layered on the internal walls of the reactor made by the following components: Au, Ga, In, P, Ge, As, Bi.

[26] Electricity generator, as described in any one of [1]-[25], wherein an artificial intelligence device optimizes in time the ratio between V, A, W, in function of the fact that increasing the Amperes the power increases exponentially with the square of the Amperes.

[27] Electricity generator, as described in any one of [1]-[26], wherein the plasma reactor is contained inside a heat exchanger that recovers the thermal energy generated by the plasma.

[28] Electricity generator, as described in any one of [1]-[27], wherein the negative resistance generated by the plasma is exploited to obtain an oscillation with an RLC circuit made by series of inductors and capacitors.

[29] Electricity generator, as described in any one of [1]-[28], wherein the artificial intelligence system directs the apparatus in a way that exploits the exponential increase of power when increasing the Amperes.

[30] Electricity generator, as described in any one of [1]-[29], that can be coupled with a LED lamp obtaining an efficiency of illumination higher than in the existent lamps of any kind.

[31] Electricity generator, as described in any one of [1]-[30], wherein the residual light inside the apparatus can be conveniently used transferring it wherever necessary by means of optic fibers, with very high efficiency.

[32] Electricity generator, as described in any one of [1]-[31], that can be used to charge the batteries of electric vehicles while they are in

motion, increasing their autonomy, just adjusting the voltage of the electricity generated to the voltage of the modules of the vehicles' batteries.

[33] A method using an electricity generator set made by a conductive hollow enclosure, made by metals or quartz containing conductors, connected with a power source that powers an electron gun made by a tungsten-hafnium alloy, upon which is a grid, , so that the electrons hit a target at the opposite side, while a magnet forces the electrons to run in straight line toward the target, and the enclosure is grounded until its hollow is saturated, so that when it is saturated MOSFET impedes the electrons to go to ground, and a diode has to allow the electrons go to a capacitor and from the capacitor to a load.

[34] Method as described in [33], to generate space charge, vacuum polarization, and virtual particles forming an electron cloud around a cathode heated in the vacuum.

[35] Method as described in any one of [33]-[34], starting from "point zero energy" makes a high dV in the ratio dV/dT enforcing the zitterbewegung of the electrons and the Aharonov-Bohm effect, changing the phases of electrons that therefore are put in clusters in coherence of phase, generating lower entropy, lower thermal capacity and less freedom degrees, transferring such excess of energy to electrons not in coherence of phase, with a consequent excess of photons emission.

Brief Description of Drawings

[0010]

Fig.1 shows a circuit diagram of an embodiment of the present invention.

Fig.2 shows a circuit diagram of an embodiment of the present invention.

Description of Embodiments

[0011]

An electricity energy is generated based on the following theory in the electricity generator of the present invention: the space charge in a vacuum-favoured space are allowed by the formation of virtual particles of matter and antimatter that shield the repulsion between electrons during their lifespan, that is inversely proportional to their mass-energy and therefore enough to allow the shielding effect, generating a lowering of the voltage required to accumulate a charge in capacitor plates and consequently generate a macroscopic voltage and an energy gain.

The gas of electrons is generated by long range electrostatic screening, derived from a vacuum polarization, generated by the creation-annihilation of virtual charges pairs as a consequence of the quantum fluctuations predicted by the Heisenberg uncertainty principle, so that electric energy is generated on the walls of the enclosure.

Therefore starting from the zero point energy derived from the Heisenberg uncertainty principle, dV/dt increase the Zitterbewegung and the Aharonov Bohm effect, causing electrons phase change, causing formation of clusters of electrons in phase, causing minor entropy, thermal capacity and freedom degrees, causing transfer of energy to electrons not in phase, causing more photon emission.

[0012]

The apparatus is made by an enclosure made by a conductive material, or a quartz tube internally containing electric conductors, for example, but not necessarily, a hollow cylinder, or a hollow cube or parallelepiped or other hollow forms.

[0013]

This cylinder has a magnet seat upon one head and an electron gun put at the opposite end of a cathode. Between the cathode and the anode a plasma is maintained, in a vacuum atmosphere and in presence of gases

like Argon, Xenon, or others and metals. The cylinder can also be made by quartz containing electric conductors.

[0014]

Upon the electron gun's cathode is put a grid, to avoid a recoil of the electrons, that are retained inside the cylinder's hollow and are directed linearly toward the opposite end, due to the magnetic field generated by the magnet.

The electron gun is charged by a power source that is grounded through a DC line, to maintain a higher potential between the cathode and the ground than between the cathode and the grid, that is connected with the conductive enclosure.

[0015]

The voltage can be also, but not necessarily, regulated by means of a Variac, depending on the power of the system.

[0016]

A MOSFET transistor (metal-oxide-semiconductor field-effect transistor) forbids the electrons to go in the circuit toward the load for 1 or several millionths of second, to allow the electrons to fill the enclosure of the cylinder, then the MOSFET opens the circuit to the ground and closes the circuit to the load.

[0017]

Along the path to the load there is a diode that allows electrons to pass only above a threshold voltage, as it is described in the embodiment. The electrons then arrive to a capacitor that shoots them to the load; this second cycle has the same duration of the first one, which is between one and several millionths of seconds.

[0018]

The MOSFET is piloted by means of a pilot transistor, charged by a frequency generator that regulates the frequency between 1 and 3 MHz, wherein the pilot transistor is put between a 1000 Ohm, 1V resistance and

a 100 Ohm, 7V resistance, the first put between the pilot and the frequency generator and the second between the pilot and a 24V battery; between the pilot and the other end of the MOSFET is put a 4V battery: in fact, since the generator cannot be able to supply a current with exactly the characteristics necessary to the MOSFET-switch, it is necessary the pilot transistor, connected as emitter in common, that amplifies the signal of the generator to correctly pilot the MOSFET-switch at high tension, that necessitates, to work properly, of a tension swing from 20V, at full conduction, to -4V at full interdiction: the MOSFET-switch has an input impedance that is almost purely capacitive at 200pF.

[0019]

The circuit of the pilot must be completed with a 1000 Ohms resistance to limit the base current of the pilot : when the signal of the generator is around 10V, in the pilot base passes a current of about 9.4 mA, the pilot conducts (in saturation) and its collector, connected to the gate of the MOSFET, is almost grounded, with VCE (sat) at several tenths of Volt, therefore the MOSFET is barred; when the signal of the generator is equal to 0 or between -1 and -2V the pilot does not conduct and the 100 Ohms resistance brings rapidly the gate of the MOSFET at 20V:

[0020]

$$\tau = R \times C$$

wherein

$$R = 100\Omega$$

$$C = 200\text{pF}$$

[0021]

The capacitor has to be maintained at a lesser voltage, limited to the breakdown voltage of the MOSFET, while its capacitance must be greater than the capacitance of the conducting enclosure and MOSFET combined.

[0022]

Before the start of the operation a high vacuum is made inside the conductive enclosure, unless the closure is maintained sealed at a fixed vacuum grade.

[0023]

A double wall thermally insulated heat exchanger recovers the heat dissipated by the system. Such heat recovery exchanger can use as a coolant any gaseous or liquid medium.

[0024]

When reached the right vacuum, it is increased and then the enclosure is forced to inspire argon or other gases until a prefixed vacuum value; at this point the enclosure can be sealed.

[0025]

All the power sources and the components of the system of the generator are connected to the omnibus ground.

[0026]

The alloy of Ga-In-P-As-Ge-Au- Bi are layered along the internal walls of the reactor all around the plasma generated between the cathode and the anode.

[0027]

The operation of the apparatus is directed by an Artificial Intelligence system that regulated the ratio between Amperes, Volts and Watts in function of the quadratic increase of the power while increasing the Amperes, along the Ohm equation:

[0028]

$$I = A^2 \times R$$

[0029]

An important application is the coupling of this apparatus with a LED lamp: in an experiment made with a customer we reached 200000 Lumens with 4 Watts of electric energy supplied from the grid to the apparatus.

[0030]

This can be very important, due to the fact that illumination absorbs the 58% of the electric energy generated in the whole world. See Photo N.1 Another possible application is to use this apparatus to charge the batteries of electric vehicles: it can supply electric charge to the batteries while the vehicle is in motion, increasing substantially the autonomy of the vehicle, just adjusting the voltage of the electricity produced to the voltage of the modules of the batteries, normally of 3.7V.

[0031]

The invention is described in the Fig. 1, whose components are:

- 1 vacuum chamber with cathode and anode made by tungsten-hafnium alloy
- 2 enclosure made by conductive metal, possibly sealed at a fixed vacuum value
- 3 vacuum pump valve
- 4 magnet
- 5 DC source between gun and grid
- 6 DC source between gun and ground ($V_6 > V_5$)
- 7 variable transformer (Variac)
- 8 power source
- 9 diode
- 10 capacitor
- 11 load
- 12 MOSFET/switch
- 13 heat sink plus fan
- 14 battery
- 15 battery
- 16 NPN transistor (pilot transistor)
- 17 resistor
- 18 BNC connector of the frequency generator
- 19 frequency generator

- 20 bus-ground
- 21 insulators
- 22 resistor
- 23 vacuum pump
- 24 AC power outlet
- 25 grid
- 26 heat recovery exchanger
- 27 transformer
- 28 zener
- 29 opto-coupler
- 30 electron gun
- 31 oscilloscope
- 32 Fresnel lens
- 33 enclosure around the plasma layered by alloys of Gallium, Indium, Phosphorus, Arsenicum, Germanium, Gold and Bismuth.
- 34 layers of the alloys described in point 33

[0032]

The values and characteristics of all these components can be modified by an expert of the art depending on the power of the system as well as the kind of conductive metal of the enclosure and the alloys of the layers upon the internal walls of the enclosure, without compromising the validity of this patent.

Experiments

[0033]

During the year 2019, 2020, AND 2021 a series of experiments have been conducted with a setup exactly equal to the embodiment in Figs 1 and 2 and the description made in this patent text, also keeping off some of the components listed above.

[0034]

It resulted in an increase of energy due to the lower impedance generated by the high vacuum and the consequent space charge generation. Also, has been measured the light residual from the apparatus, that is suitable to be used and diffused anywhere by means of optic fibres. The light resulted to be yielded with a very high efficiency.

[0035]

The experiment has been performed in the laboratory of Leonardo Corporation in Miami Beach, Florida (USA) and in Rome (ITALY) described in the following report:

www.researchgate.net/publication/330601653_E-Cat_SK_and_long_range_particle_interactions

[0036]

The circuit was composed by all the components described in the embodiment and such components have been connected exactly as described in the Fig. 1 and 2 of which we can give hereunder a more precise detail:

[0037]

■FIG. 1

In the embodiment, besides the numbers above described in the legends, there are codes that we explain now.

R1 is the resistive load of 1kW.

R2 polarizes the pilot NPN transistor, 820Ohm ½W.

R3 polarizes the zener Z1, 4.7V, 10W.

R4 is 100Ohm, 7W, brings the gate of the MOSFET to +20V respect the source when T1 is barred.

R5 is 820Ohm, 1W, limits the current in the LED internal to the opto-coupler.

RTEST is 10Ohm, ½W to monitor by the oscilloscope of the drain current of the MOSFET.

[0038]

The condensers are all ceramic:

C1 is the condenser of 0.15nF, 1700V

C2 is the condenser of 100nF, 50V to lower the dynamic impedance of the zener and to lower its noise.

C3 is a condenser of 100nF of by-pass of the 24V battery.

C4 is a condenser of 100nF, low tension, demanded by the opto-coupler. Must be connected close to the opto-coupler's connections 4 and 6.

C5 is a condenser of 50nF, low tension of by-pass of the cathode.

Z1 is the zener, to allow the current go reverse direction when the voltage is reached.

D1 is the diode high tension, high speed.

U1 is the opto-coupler to isolate the Siglent of the switch circuit.

T1 is the pilot transistor.

T2 is the MOSFET SiC transistor, the switch that alternates the two modalities of the system.

PH are the chips of semiconductors.

AI is the artificial Intelligence that balances the ratio A/V and power.

HX is the heat exchanger to recover the heat irradiated by the plasma.

L is the layer of alloys of Au, Ge, P, Ga, In, As, Bi.

[0040]

The whole switch circuit must be well isolated from the omnibus ground.

The connection 2 indicated at the batteries is the positive pole.

The Siglent must be regulated to exit a square wave +5V HI 0V LOW, 50% duty cycle, frequency 1-5MHz.

The transistors must be well isolated from the heat sinks.

[0041]

■FIG. 2

FIG. 2 shows the anode connected with an inductor that exploiting the negative resistance of the plasma, due to the enrichment of the

electrons emitted between cathode and anode, makes an RLC oscillation in circuit with a series of capacitors and inductors.

[0042]

Components of this schematic can also be modified by experts of the art, but since they will operate on the same principle, such mutations will not affect the validity of this patent.

[0043]

It will be appreciated by persons skilled in the art that numerous variations and/or modifications may be made to the above-described embodiments, without departing from the broad general scope of the present disclosure. The present embodiments are, therefore, to be considered in all respects as illustrative and not restrictive.

[0044]

Throughout this specification and the claims which follow, unless the context requires otherwise, the word "comprise", and variations such as "comprises" and "comprising", will be understood to imply the inclusion of a stated integer or step or group of integers or steps but not the exclusion of any other integer or step or group of integers or steps.

[0045]

The reference to any prior art in this specification is not, and should not be taken as, an acknowledgement or any form of suggestion that the prior art forms part of the common general knowledge in Australia.

Claims

1. An electricity generator set made by a conductive hollow enclosure, made by metals or quartz containing conductors, connected with a power source that powers an electron gun made by a tungsten-hafnium alloy, upon which is a grid, so that the electrons hit a target at the opposite side, while a magnet forces the electrons to run in straight line toward the target, and the enclosure is grounded until its hollow is saturated, so that when it is saturated MOSFET impedes the electrons to go to ground, and a diode has to allow the electrons go to a capacitor and from the capacitor to a load.

2. The electricity generator according to claim 1, wherein the MOSFET is piloted with an NPN transistor put between two resistances and powered by a frequency generator.

3. The electricity generator according to claim 2, wherein one resistance is put between a DC energy source and the NPN transistor and the other is put between the pilot transistor and the connection with the frequency generator.

4. The electricity generator according to claim 2 or 3, wherein a DC current source is put between the MOSFET and the NPN transistor.

5. The electricity generator according to any one of claims 1-4, wherein the MOSFET generates the frequency necessary to alternate the phase in which the electrons go to ground and the phase during which they go to the load.

6. The electricity generator according to any one of claims 1-5, wherein a vacuum pump makes the vacuum in the enclosure through a

valve and the vacuum contains Ar, or other gases and metals, possibly the enclosure being sealed at a fixed vacuum grade.

7. The electricity generator according to any one of claims 1-6, wherein the electron gun is powered by a DC power source with a voltage lower than the voltage of the wire that connects it with the ground, that is fed by means of a DC current source.

8. The electricity generator according to any one of claims 1-7, wherein the DC current that go to the electrons gun and the ground wire is modulated by means of a variable transformer (Variac).

9. The electricity generator according to any one of claims 1-8, wherein the electron gun is electrically insulated from the enclosure by means of proper insulating materials.

10. The electricity generator according to any one of claims 1-9, wherein the enclosure is double walled by a heat exchanger to recover the heat dissipated from the generator.

11. The electricity generator according to any one of claims 1-10, wherein the electron gun is charged by means of a source that is grounded through a DC line to maintain a higher potential between the cathode and the ground respect the voltage between the cathode and the grid connected to the enclosure.

12. The electricity generator according to any one of claims 1-11, wherein the capacitor must have a voltage not higher than the breakdown voltage of the MOSFET and a capacitance higher than the capacitances of the enclosure and the MOSFET combined.

13. The electricity generator according to any one of claims 1-12, wherein the MOSFET is connected to a NPN transistor, put between two resistances, so that the signal arriving from a frequency generator is maintained exactly at the value at which the MOSFET has to work and one DC source is put between the NPN transistor and the generator and another DC source is put between the MOSFET and the ground.

14. The electricity generator according to any one of claims 1-13, wherein a resistance polarizes the NPN pilot, a resistance polarizes the zener, a resistance brings the gate of the MOSFET to a +20V voltage respect the source when the NPN transistor is barred, a resistance limits the current to the led of the opto-coupler.

15. The electricity generator according to any one of claims 1-14, wherein a condenser accumulates the electrons to be sent to the load, a condenser lowers the impedance of the zener, a condenser is for by pass of the 24 V battery, a condenser is connected to the opto-coupler, a condenser is a by-pass of the cathode.

16. The electricity generator according to any one of claims 1-15, wherein is a zener to reverse the current when the voltage is reached between the enclosure and the MOSFET.

17. The electricity generator according to claims 16, wherein a diode allows the current to go toward the capacitor when the voltage is reached.

18. The electricity generator according to claim 16, wherein an opto-coupler isolates the frequency generator (Siglent) from the switch circuit.

19. The electricity generator according to claim 16, wherein a NPN transistor addresses the current to the SiC-MOSFET.

20. The electricity generator according to claim 16, wherein a SiC-MOSFET regulates the alternate cycles of the process, allowing the current to go to ground or to the enclosure.

21. The electricity generator according to any one of claims 1-20, wherein the plasma is surrounded by alloys layered on the internal walls of the reactor made by the following components: Au, Ga, In, P, Ge, As, Bi.

22. The electricity generator according to any one of claims 1-21, wherein an artificial intelligence device optimizes in time the ratio between V, A, W, in function of the fact that increasing the Amperes the power increases exponentially with the square of the Amperes.

23. The electricity generator according to any one of claims 1-22, wherein the plasma reactor is contained inside a heat exchanger that recovers the thermal energy generated by the plasma.

24. The electricity generator according to any one of claims 1-23, wherein the negative resistance generated by the plasma is exploited to obtain an oscillation with an RLC circuit made by series of inductors and capacitors.

25. The electricity generator according to any one of claims 1-24, wherein the artificial intelligence system directs the apparatus in a way that exploits the exponential increase of power when increasing the Amperes.

26. The electricity generator according to any one of claims 1-25, that can be coupled with a LED lamp obtaining an efficiency of illumination higher than in the existent lamps of any kind.

27. The electricity generator according to any one of claims 1-26, wherein the residual light inside the apparatus can be conveniently used transferring it wherever necessary by means of optic fibres, with very high efficiency.

28. The electricity generator according to any one of claims 1-27, that can be used to charge the batteries of electric vehicles while they are in motion, increasing their autonomy, just adjusting the voltage of the electricity generated to the voltage of the modules of the vehicles' batteries.

29. A method using an electricity generator set made by a conductive hollow enclosure, made by metals or quartz containing conductors, connected with a power source that powers an electron gun made by a tungsten-hafnium alloy, upon which is a grid, , so that the electrons hit a target at the opposite side, while a magnet forces the electrons to run in straight line toward the target, and the enclosure is grounded until its hollow is saturated, so that when it is saturated MOSFET impedes the electrons to go to ground, and a diode has to allow the electrons go to a capacitor and from the capacitor to a load.

30. The method according to claim 29, to generate space charge, vacuum polarization, and virtual particles forming an electron cloud around a cathode heated in the vacuum.

31. The method according to claim 29 or 30, starting from "point zero energy" makes a high dV in the ratio dV/dT enforcing the zitterbewegung

of the electrons and the Aharonov-Bohm effect , changing the phases of electrons that therefore are put in clusters in coherence of phase, generating lower entropy, lower thermal capacity and less freedom degrees, transferring such excess of energy to electrons not in coherence of phase, with a consequent excess of photons emission.

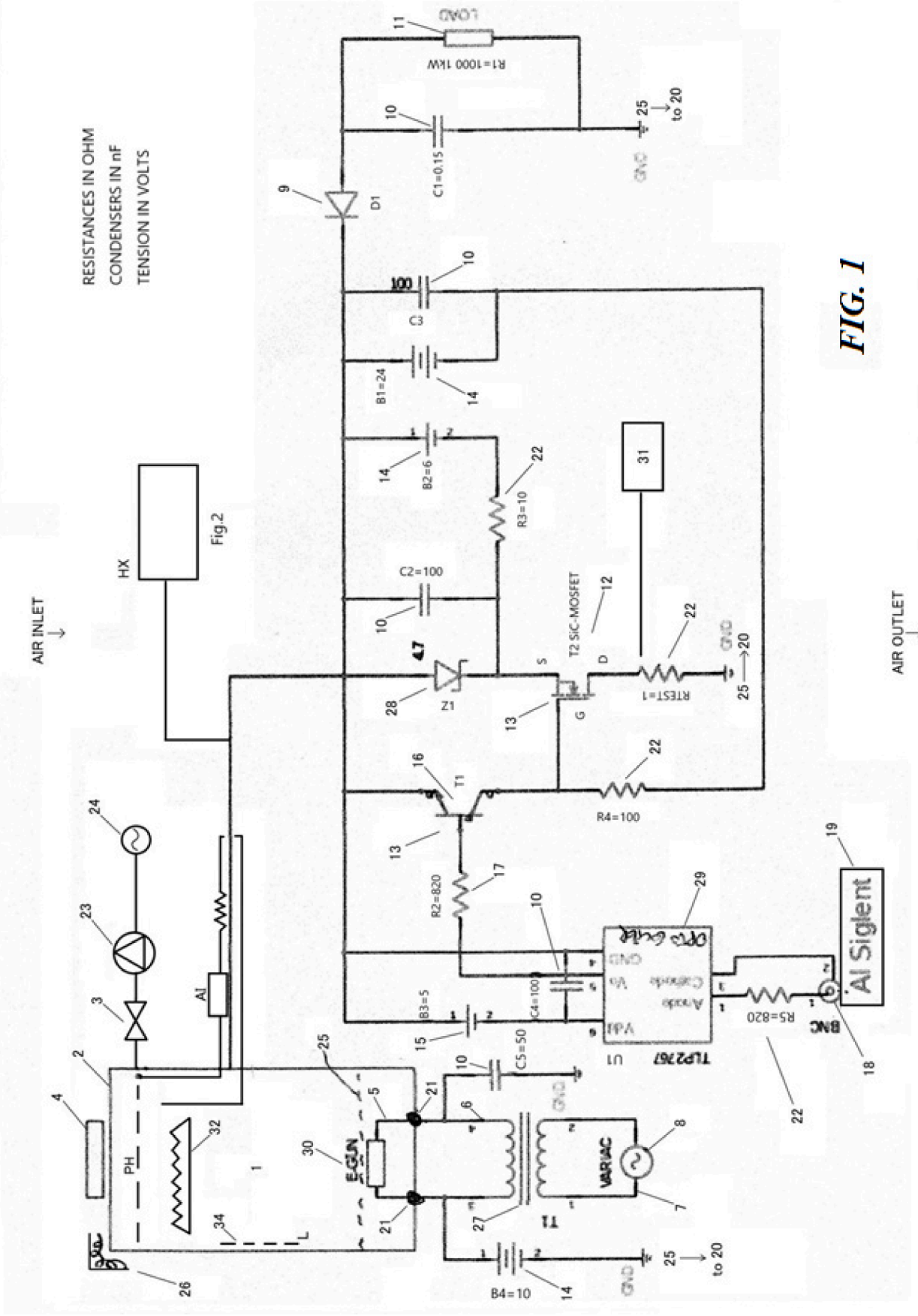

FIG. 1

- L3 77 turns, 210 μ H } INDUCTORS
- L2 8 turns }
- C4, C5 4.7nF (disc shaped capacitors)
- C6, C7 3.5nF (variable capacitor)
- C3 polipropilene capacitor 3 μ F
- V Negative current source E-Cat SK

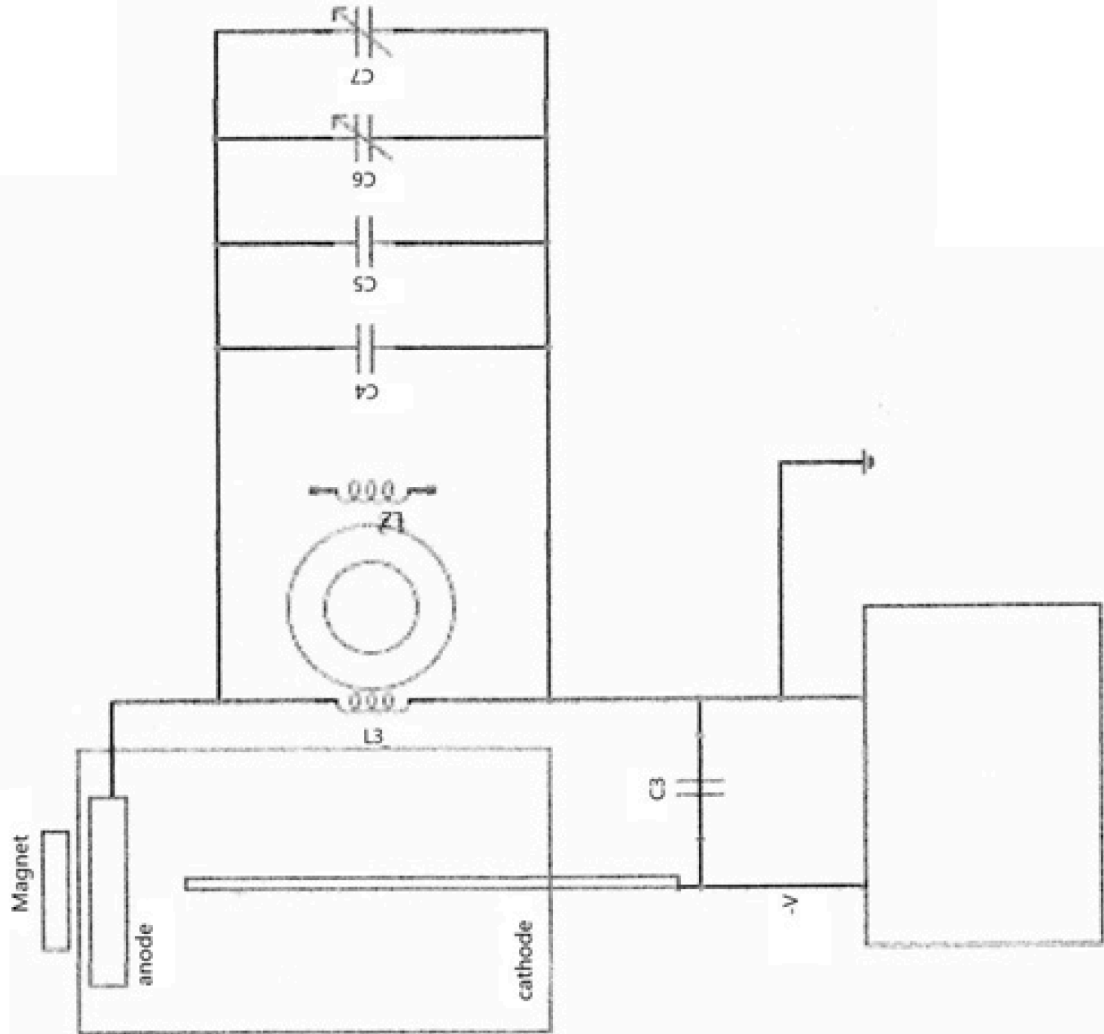

FIG. 2